

**WATERFALL AUDIO**  
SOUND DESIGNERS



DATA SHEET  
**HURRICANE EVO SHELF STAND**

Made in France

**KEY POINTS**

- Metal shelf stand compatible with Hurricane Evo
- Available in black or white

## HURRICANE EVO

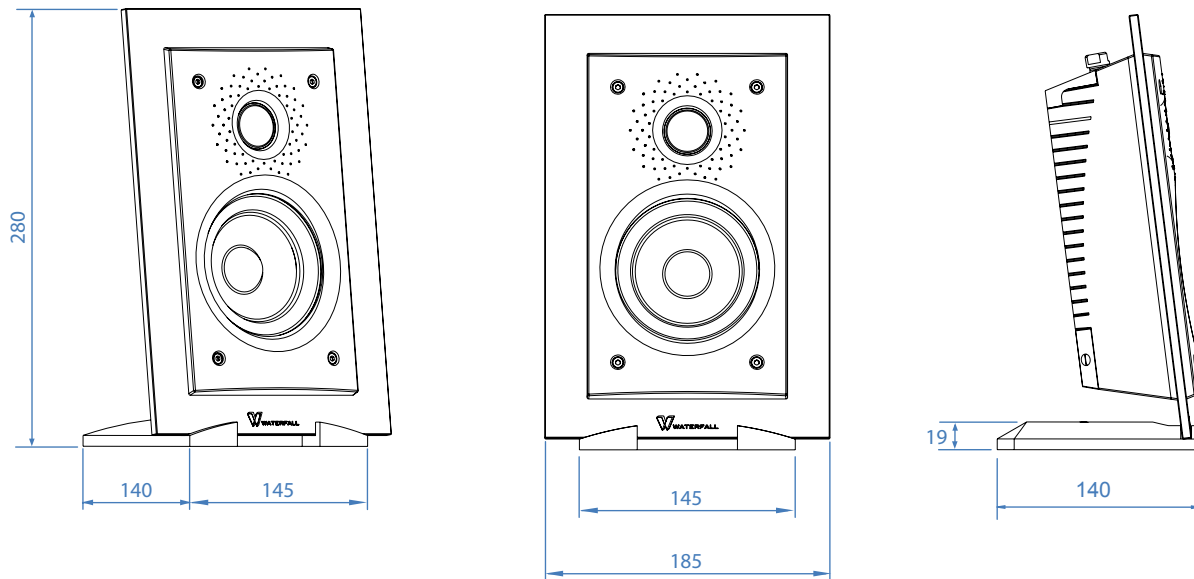

### TECHNICAL DETAILS

TYPE	Shelf stand accessory
DIMENSIONS (width x depth x height in mm) (approx. inches)	145 x 140 x 19 / 5.71" x 5.5" x 0.75"
WEIGHT Kg (approx. lbs.)	

### WATERFALL AUDIO

ZA les praderies - 83 570 Carcès - France  
Phone: **+33 (0)4 98 05 11 30**  
**export@waterfallaudio.com**

Made in France. 5 years warranty on speakers, 2 years warranty on amplifiers (parts & service).  
We operate a policy of continuous improvement and reserve the right to amend designs and specifications without prior notice.

 All drivers are developed and manufactured by Atohm (France).